

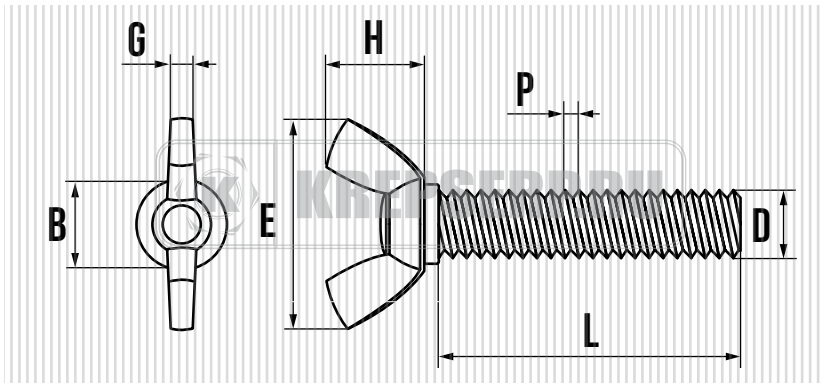

ВИНТ-БАРАШЕК ИЗ НЕРЖАВЕЮЩЕЙ СТАЛИ DIN 316

**ХАРАКТЕРИСТИКИ:**

- DIN 316
- НЕРЖАВЕЮЩАЯ СТАЛЬ А-2, А-4
- МЕТРИЧЕСКАЯ РЕЗЬБА
- ГОЛОВКА-БАРАШЕК

ПРИМЕНЕНИЕ

КРЕПЛЕНИЕ И СОЕДИНЕНИЕ УЗЛОВ И ДЕТАЛЕЙ В МАШИНОСТРОЕНИИ, СТРОИТЕЛЬСТВЕ, ТАМ, ГДЕ ТРЕБУЕТСЯ БЫСТРАЯ И ЧАСТАЯ РАЗБОРКА – СБОРКА КРЕПЁЖНОГО СОЕДИНЕНИЯ. ВИНТ СНАБЖЕН «БАРАШКОМ» ДЛЯ ЗАКРУЧИВАНИЯ – ОТКРУЧИВАНИЯ ВРУЧНУЮ, ЧТО ПОЗВОЛЯЕТ РАБОТАТЬ БЕЗ СПЕЦИАЛЬНЫХ ИНСТРУМЕНТОВ.

ОБОЗНАЧЕНИЕ	D мм.	L мм.	E мм.	H мм.	B мм.	G мм.	P шаг резьбы
M4	4	16	22	10,5	10,0	2,5	0,7
M4	4	20	22	10,5	10,0	2,5	0,7
M4	4	25	22	10,5	10,0	2,5	0,7
M4	4	30	22	10,5	10,0	2,5	0,7
M5	5	10	22	13,0	10,0	3,0	0,8
M5	5	16	22	13,0	10,0	3,0	0,8
M5	5	20	22	13,0	10,0	3,0	0,8
M5	5	25	22	13,0	10,0	3,0	0,8
M5	5	30	22	13,0	10,0	3,0	0,8
M6	6	10	27	17,0	12,0	4,0	1,0
M6	6	12	27	17,0	12,0	4,0	1,0
M6	6	16	27	17,0	12,0	4,0	1,0
M6	6	20	27	17,0	12,0	4,0	1,0
M6	6	25	27	17,0	12,0	4,0	1,0
M6	6	30	27	17,0	12,0	4,0	1,0
M6	6	40	27	17,0	12,0	4,0	1,0
M8	8	16	31	20,0	14,0	4,0	1,25
M8	8	20	31	20,0	14,0	4,0	1,25
M8	8	25	31	20,0	14,0	4,0	1,25
M8	8	30	31	20,0	14,0	4,0	1,25
M8	8	40	31	20,0	14,0	4,0	1,25
M8	8	50	31	20,0	14,0	4,0	1,25
M10	10	16	35	33,5	16,0	5,0	1,25
M10	10	20	35	33,5	16,0	5,0	1,25
M10	10	25	35	33,5	16,0	5,0	1,25
M10	10	30	35	33,5	16,0	5,0	1,25
M10	10	40	35	33,5	16,0	5,0	1,25
M10	10	50	35	33,5	16,0	5,0	1,25